



ABOVE AND BEYOND HONING

# SV-2500 SERIES

PRECISION VERTICAL HONING SYSTEM



# SUNNEN'S SV-2500 SERIES: PRECISION, 3-AXIS



Sunnen has long set the industry standard in creating complete solutions for precision honing, and the SV-2500 Series Vertical Honing System represents another milestone in Sunnen's pursuit of innovation.

The SV-2500 Series features a patented stroke control system for solving difficult applications which offers three-axis servo-control of spindle rotation, stroke and tool feed, allowing the machine to produce a whole-bore, constant crosshatch angle to meet the precision requirements for diesel and gasoline engines, cylinder liners, and other large part applications.

Synchronized servo axes allow your operator to set the desired crosshatch angle using the Windows®-based control, or change it mid-cycle – eliminating the 'flattening' of the crosshatch angle that all other honing machines produce at the stroke-reversal point.

The SV-2500 is the basic module of a *system series* that allows us to create a custom-designed processing solution tailored to your specific needs:



# SERVO-CONTROLLED HONING SYSTEMS



- The versatile SV-2500 is available in single-spindle, or multiple-spindle configurations and with either manual or fully automated parts loading. There are three base models to choose from -- SV-2500, SV-2510 and SV-2560
- We'll create each solution as an optimized package, including custom guarding, part-handling automation, custom risers and fixturing, tooling, abrasives, gaging and coolants, as your needs require.

The SV-2500 Series offers great size and flexibility advantages over comparable high-production honing systems. And when it's a part of a total Sunnen solution, the SV-2500 will provide you a durable and efficient precision honing system to perform to your exact production and application needs.

*Sunnen's technical specialists have developed servo drive and motion control technology that delivers constant crosshatch throughout the entire length of the bore – virtually impossible to achieve until now. With the all-electric drive system, the servo-accurate reversal points will not drift over time, plus the leakage, noise, maintenance, heat generation, and size control problems presented by typical competitor's hydraulic systems are avoided.*

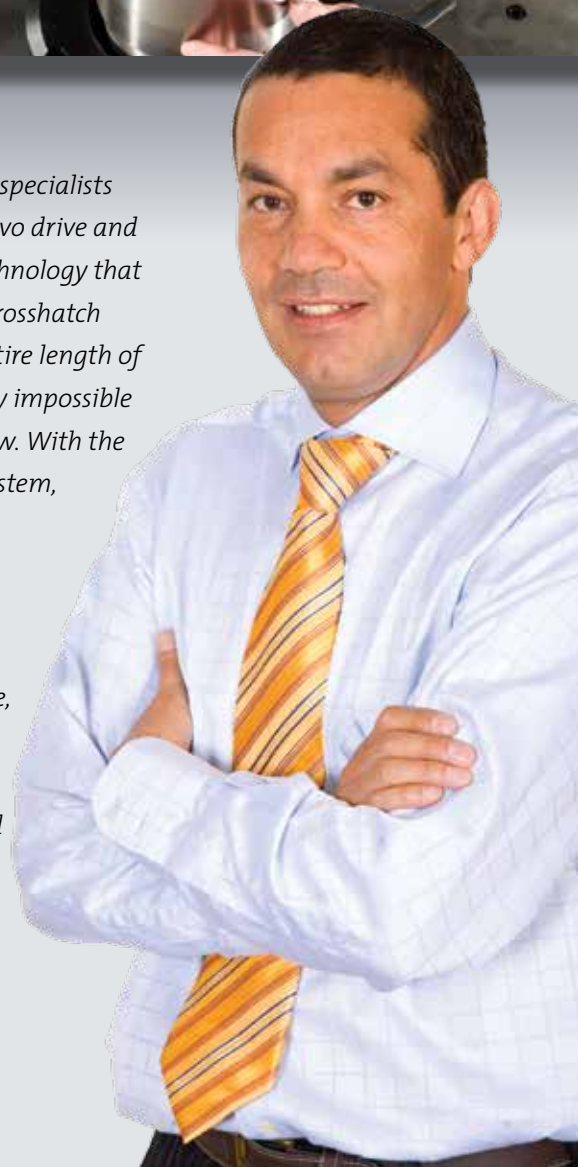

## THE SV-2500 COMBINES MULTI-SPINDLE PROCESSING FLEXIBILITY WITH FAST CYCLE TIMES.

**WINDOWS®-BASED PC CONTROL** simplifies the honing process to allow anyone with multi-axis experience to run this machine like an expert. Plus, the control system features easy-to-use drop-down menus and a large storage capacity for saving job setups for later use.

**SYNCHRONIZED SERVO MOTORS** for stroke and spindle maintain constant crosshatch finish throughout the bore, from end to end. Patented stroke control for difficult applications

**CONSTANT TORQUE 7.5 kW (10 HP) SPINDLE** permits high stock removal rates on even tough material like compacted-graphite iron. Standard spindle speed is 0-300 rpm – with an option of 0-600 rpm – and a maximum stroke rate of 160 spm.

**FAST CHANGEOVER:**  
Most tools can be changed in less than five minutes.

**LOW MAINTENANCE** stainless steel work area will not corrode or fade. Custom guarding (not shown) is available for multi-spindle configurations and automation options. CE Compliant.

**OPEN BASE DESIGN** allows for the pass-through of large parts and makes the SV-2500 perfect for the parallel manufacturing configuration in a lean environment. Also permits ease of adding automation and other customized options.

**AUTO DWELL FEATURE** corrects bore straightness automatically – great for blind bores.

**CAST IRON BASE AND COLUMN** provides rugged durability and reduced vibration in a small footprint. Custom bases available for multi-spindle configurations.



## SV-2560 Floor Plan

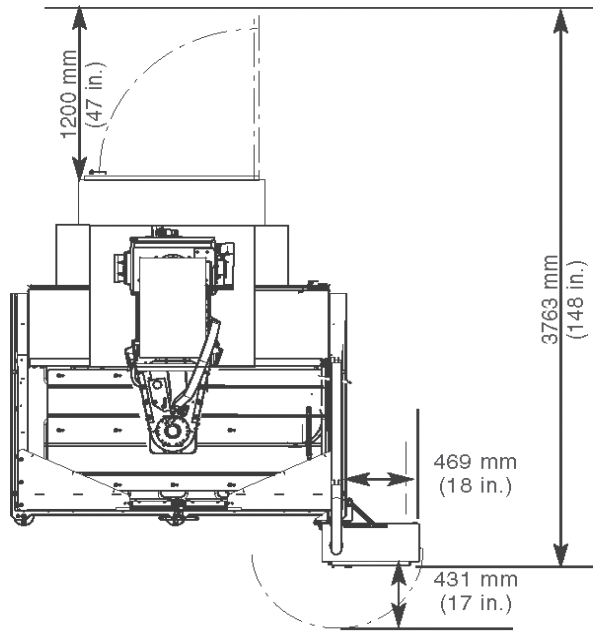

TOP VIEW

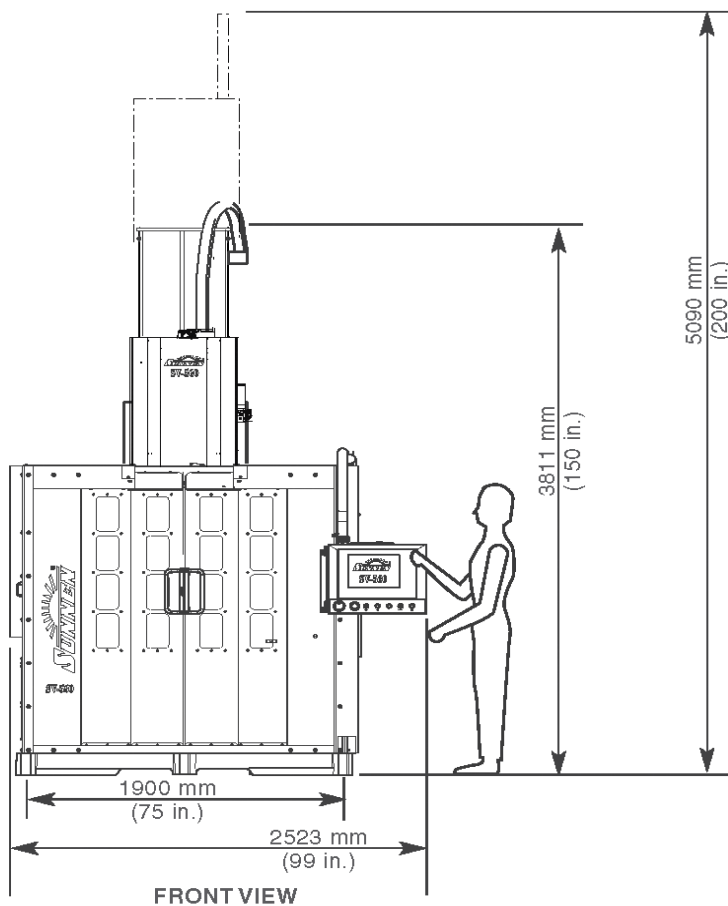

### WELL SUITED FOR A WIDE RANGE OF APPLICATIONS

The SV-2500 Vertical Honing System is ideal for diesel cylinder liners, mud pump liners, large hydraulic blocks, brake drums and other mid- to high-production applications.



### CONSTANT CROSSHATCH CAPABILITY

Sunnens's SV-2500 has a synchronized servo stroke motor and spindle for a constant crosshatch finish throughout the bore with no rollover.





## CUSTOMIZE THE SV-2500 SERIES TO YOUR EXACT REQUIREMENTS

Sunnen's high-precision honing systems represent the very finest solutions available anywhere in the world. They are reliable, durable, and flexible systems designed to deliver the production quality and precision our customers have grown to expect.

From design to delivery, you have the Sunnen commitment to service and quality assurance. Our technical experts will work with you to determine the number of spindles, style of tooling, fixturing, abrasives, in-process and/or post-process gaging, and method of parts loading and unloading (including robotics) you require. Then we'll provide you a written proposal.

After your system is built, we'll set up a live run-off demonstration at our facility. Once it meets all specifications, we'll commission your system and train your staff.

### SV-2500 SERIES AUTOMATION OPTIONS



A TWO-AXIS OR MULTI-AXIS SERVO ROBOT CAN BE INTEGRATED INTO A SUNNEN MODULAR HONING SYSTEM.

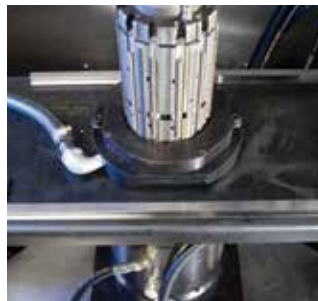

INTEGRATED AIR SIZING SYSTEMS CONTROL THE ACCURACY OF BOTH ROUGHING AND FINISHING PROCESSES.

### MACHINE OPTIONS

- Elevated fixture frame
- Robot interface
- Automation PLC
- Multiple columns
- Custom risers for long parts
- Light stack
- Work area lights
- Mist elimination system
- Pneumatic panel for control of pneumatic fixturing on in-process air gaging
- Guide pot assembly
- In-process air gaging
- Servo and manual rollover cradles
- Custom guarding

#### SPECIFICATIONS:

##### DIAMETER RANGE (ID): \*

19 - 229 mm (.75 - 9 in.)

**WORKPIECE WEIGHT:**\* 900 kg (2000 lbs.)

##### WORK AREA ENVELOPE:

1016 x 1778 mm (40 x 70 in.)

##### STROKE TRAVEL:\*

SV-2500 - Up to 762 mm (30 in.)

SV-2510 - Up to 762 mm (30 in.)

SV-2560 - Up to 1524 mm (60 in.)

##### RECIPROICATION RATE (STROKE - Z AXIS):

##### SV-2500/2510/2560:

Up to 160 strokes per minute

**STROKE MOTOR:** Servo 7.5 kW (10 hp)

##### SPINDLE SPEEDS:

SV-2500: 0 to 300 RPM (600 RPM optional)

SV-2510: 0 to 300 RPM (600 RPM optional)

SV-2560: 0 to 300 RPM

**SPINDLE MOTOR: SERVO** 7,5 kW (10 hp)

360 N-M (265 ft. lbs) torque

**FEED:** Servo Linear Push/Pull

##### X-AXIS (SV-2510 ONLY):

**TRAVEL:** 1143 MM (45 IN.)

**SPEED:** .001 - .085 MPS (.04-.335 IPS)

**COOLANT SUMP PUMP:** 0,5 kW (.67 hp)

centrifugal pump/ 205 LPM (68 GPM)

##### FLOOR SPACE/MACHINE FOOT PRINT

(WITHOUT COOLANT TANK OPTION)

##### SV-2500/2510:

2210 W x 2056 D x 2275 H mm

(87 x 81 x 89.5 in.)

##### SV-2560:

2600 W x 2613 D x 5090 H mm

(102 x 103 x 200 in.)

##### FLOOR WEIGHT:

SV-2500/2510: 5443 kg (12,000 lbs.)

SV-2560: 5620 kg (12,500 lbs.)

##### FLOOR LOAD:

##### SV-2500/2510:

1500 kg/sq. meter (301 lbs./sq. ft)

##### SV-2560:

2050 kg/sq. meter (415 lbs./ sq. ft.)

##### ELECTRICAL REQUIREMENTS:

- 460V, 60Hz, 3Ph (43 FLA - full load amps)

- 400V, 50Hz, 3Ph (46 FLA - full load amps)

##### NOISE EMISSION:

Less than 72 dB(A) continuous load (max. noise) condition in a factory environment.

\* DIAMETER RANGE, LENGTH RANGE AND WORKPIECE WEIGHT ARE CONTINGENT ON WORKPIECE AND APPLICATION.

## TOOLING

Sunnen offers flexible, precision tooling for the SV-2500 that delivers precise, accurate and consistent bore sizing.

### PH PRECISION MULTI-STONE HONING TOOLS

New features on this line of multi-stone honing tools optimize bore geometry and efficiency in mid- and high-volume production applications.

Tools can be built to meet any need, and are available in single-stage and two-stage models. PH tools can hold 12 or more stones to produce optimum straightness and roundness. Available with integral plug sizing or in-process air gaging.

### BORE DIAMETER RANGE:

50 mm - 229 mm (2 inches - 9 inches)

*NOTE: FOR DIAMETER SIZES BELOW 50, OR ABOVE 30 MM, OR FOR SPECIALLY DESIGNED HIGH PRODUCTION TOOLS, CONTACT YOUR SUNNEN FIELD ENGINEER.*



## SUNNEN-MADE ABRASIVES

From aluminum oxide to silicon carbide to diamond and CBN, Sunnen manufactures the industry's largest variety of mounted or un-mounted stick abrasives, bond types, grain sizes and stone configurations.

Before any stone is shipped, it is graded and qualified, maintaining the most exacting quality control standards in the industry to assure you of the most precise and consistent honing performance available.



## SUNNEN PREMIUM HONING OILS & COOLANTS

Sunnen's premium honing oils and coolants provide extreme lubricity for higher honing pressure and harder abrasives, delivering faster, lower cost-per-part and ultimately more profitable cutting rates.

## SUNNEN DIAL BORE GAGES

Sunnen Dial Bore Gage system provides quick, easy way to gage I.D's on bores with a wide range of sizes and lengths. Dial Bore Gages and Setting Fixtures are available to cover diameters from 13,71 to 152,4 mm (.054 to 5 in), optional to 309 mm (12 in).





A LEGACY OF EXCELLENCE SINCE 1924.

## WORLDWIDE

Our global manufacturing, distribution, and sales and service network allows us to deliver quality Sunnen solutions worldwide.

And our state-of-the-art Technical Services Centers allow our technical experts to develop innovative solutions to customer application challenges. The Centers also provide answers for customer questions and training for Sunnen representatives around the world.

**SUNNEN PRODUCTS COMPANY**  
**WORLD HEADQUARTERS**  
**St. Louis, MO – USA**  
Phone 1.314.781.2100  
Fax 1.314.781.2268  
Toll Free 1.800.325.3670  
Email [sunnen@sunnen.com](mailto:sunnen@sunnen.com)  
[www.sunnen.com](http://www.sunnen.com)



### **AUSTRIA - SUNNEN AUSTRIA GMBH** **HOHENEMS**

Phone +43 5576 74194  
Fax +43 5576 74196  
Email [sales@sunnen.eu](mailto:sales@sunnen.eu)  
[www.sunnen.at](http://www.sunnen.at)

### **BELGIUM - SUNNEN BENELUX BVBA** **KONTICH**

Phone +32 38 80 2800  
Fax +32 38 44 3901  
Email [info@sunnen.be](mailto:info@sunnen.be)  
[www.sunnen.be](http://www.sunnen.be)

### **BRAZIL - SUNNEN DO BRASIL LTDA.** **SÃO PAULO**

Phone +55 11 4177-3824  
Fax +55 11 4362-3083  
Email [sunnen@sunnen.com.br](mailto:sunnen@sunnen.com.br)  
[www.sunnen.com.br](http://www.sunnen.com.br)

### **CHINA - SHANGHAI SUNNEN** **MECHANICAL Co. LTD.**

**SHANGHAI**  
Phone +86 21 5813 3990  
Fax +86 21 5813 2299  
Email [shsunnen@sunnensh.com](mailto:shsunnen@sunnensh.com)  
[www.sunnensh.com](http://www.sunnensh.com)

### **CZECH REPUBLIC - SUNNEN S.R.O.** **STRAKONICE**

Phone +420 383 376 317  
Fax +420 383 376 316  
Email [sunnen@sunnen.cz](mailto:sunnen@sunnen.cz)  
[www.sunnen.cz](http://www.sunnen.cz)

### **FRANCE - SUNNEN SAS**

**SACLAY**  
Phone +33 169 30 00 00  
Fax +33 169 30 11 11  
Email [info@sunnen.fr](mailto:info@sunnen.fr)  
[www.sunnen.fr](http://www.sunnen.fr)

### **INDIA - SUNNEN INDIA PVT. LTD.** **MUMBAI**

Phone +91 223 913 6055  
Fax +91 223 913 6056  
Email [sales@sunnen.in](mailto:sales@sunnen.in)  
[www.sunnen.in](http://www.sunnen.in)

### **ITALY - SUNNEN ITALIA S.R.L.** **ARESE**

Phone +39 02 383 417 1  
Fax +39 02 383 417 50  
Email [sunnen@sunnenitalia.com](mailto:sunnen@sunnenitalia.com)  
[www.sunnenitalia.com](http://www.sunnenitalia.com)

### **POLAND - SUNNEN POLSKA Sp. z o.o.** **WARZAWA**

Phone +48 22 814 34 29  
Fax +48 22 814 34 28  
Email [sunnen@sunnen.pl](mailto:sunnen@sunnen.pl)  
[www.sunnen.pl](http://www.sunnen.pl)

### **SUNNEN RUS LLC** **MOSCOW – RUSSIA**

Phone +7 495 258 43 43  
Fax +7 495 258 91 75  
Email [sunnen@sunnen-russia.ru](mailto:sunnen@sunnen-russia.ru)  
[www.sunnen.ru](http://www.sunnen.ru)

### **SWITZERLAND - SUNNEN AG** **ENNETAACH**

Phone +41 71 649 33 33  
Fax +41 71 649 33 34  
Email [sales@sunnen.eu](mailto:sales@sunnen.eu)  
[www.sunnen.eu](http://www.sunnen.eu)

### **UK - SUNNEN PRODUCTS LTD.** **HEMPSTEAD HERTS**

Phone +44 1442 39 39 39  
Fax +44 1442 39 12 12  
Email [hemel@sunnen.co.uk](mailto:hemel@sunnen.co.uk)  
[www.sunnen.co.uk](http://www.sunnen.co.uk)

Sunnen reserves the right to change or revise specifications and product design in connection with any feature of our products contained herein. Such changes do not entitle the buyer to corresponding changes, improvements, additions, or replacements for equipment, supplies or accessories previously sold. Information contained herein is considered to be accurate based on available information at the time of printing. Should any discrepancy of information arise, Sunnen recommends that user verify the discrepancy with Sunnen before proceeding.